



<b>Project Name</b> : Untitled project 2025-03-21 17:37:15.521	<b>Project ID</b> :
<b>Company Name</b> :	
<b>Department</b> :	
<b>Phone number</b> :	
<b>e-mail address</b> :	

## Requested Data

<b>Flow</b> : 124.9 m <sup>3</sup> /h	<b>Fluid</b> : Water
<b>Head</b> : 103 m	<b>Density</b> : 0.9983 kg/dm <sup>3</sup>
	<b>Viscosity</b> : 1.005 mm <sup>2</sup> /s
	<b>Temperature</b> : 20 °C
	<b>pH-value at t A</b> :
	<b>Vapour pressure at t A</b> : 0.0234 bar

## Pump

<b>Pump Model</b> : S10S-125/05	<b>Minimum Continuous Flow</b> : 40 m <sup>3</sup> /h
<b>No. of Stages</b> : 5	<b>Flow Nominal</b> : 124.6 m <sup>3</sup> /h
<b>Outlet Size</b> : 150	<b>Max-</b> : 162.2 m <sup>3</sup> /h
<b>Speed</b> : 2900 1/min	<b>Min-</b> : 40 m <sup>3</sup> /h
<b>Direction of Rotation</b> : Counter clockwise	<b>Head Nominal</b> : 102.1 m
<b>Impeller type</b> : Mixed Flow Impeller	<b>Max-</b> : 142 m
<b>Impeller Design</b> : Closed	<b>Min-</b> : 68.58 m
<b>pump weight(Approx)</b> : 55.2 kg	<b>Efficiency Overall Efficiency</b> : 68.59 %
<b>Pump Standard</b> :	<b>Pump Efficiency</b> : 80.05 %

## Motor

<b>Motor Model</b> : W8B-550DI	<b>Motor Standard</b> :
<b>Frequency</b> : 50 Hz	<b>Insulation Class</b> : Y
<b>Phase</b> : 3~	<b>Degree of Protection</b> : IP 68
<b>Rated Voltage</b> : 380 V	<b>Method of Starting</b> : Star-delta
<b>Rated current</b> : 116 A	<b>Service factor</b> : 1
<b>Rated Power P2</b> : 55 kW	<b>Power factor</b> : 0.87
<b>Speed</b> : 2900 1/min	<b>No.of.starts per hour</b> : 15
<b>Efficiency</b> : 84.5 %	<b>Starting current</b> :
<b>Motor Weight (Approx)</b> : 180 kg	<b>Starting torque</b> :

## Material of Construction

Pump		Motor	
<b>Check Valve Housing</b>	S.S 304	<b>Shaft Seal Housing</b>	Cast Iron
<b>Check Valve Disc</b>	S.S 304	<b>Shaft Seal / Mechanical Seal</b>	Nitrile Rubber / Ceramic - Carbon , SiC
<b>Check Valve Seat</b>	Nitrile Butyle Rubber	<b>Upper &amp; Lower Housings</b>	Cast Iron
<b>Diffuser Chamber</b>	S.S 304	<b>Stator Shell</b>	SS 304
<b>Impeller</b>	S.S 304	<b>Thrust Pad</b>	Carbon Graphite
<b>Split Cone with Nut</b>	S.S 304	<b>Thrust Bearing</b>	SS 420
<b>Impeller Wearing / Seal Ring</b>	Nitrile Butyle Rubber	<b>Diaphragm</b>	High Nitrile Rubber
<b>Upthrust Washer / Stop Ring</b>	S.S 420	<b>Motor Base</b>	Cast Iron
<b>Intermediate Bearing</b>	Nitrile Butyle Rubber	<b>Shaft</b>	EN-8
<b>Suction Interconnector</b>	S.S 304	<b>Shaft Extension</b>	S.S 410
<b>Inlet Screen</b>	S.S 304	<b>Sleeves</b>	SS 431
<b>Pump Shaft</b>	S.S 431		
<b>Coupling Splines</b>	S.S 329		
<b>Locking Strap</b>	S.S 304		
<b>Cable Guard</b>	S.S 304		



**Project Name** : Untitled project 2025-03-21 17:37:15.521

**Project ID** :

**Company Name** :

**Department** :

**Phone number** :

**e-mail address** :

**Curve Tolerance** ISO : 9906, Grade-3B

**Speed** 2900 rpm

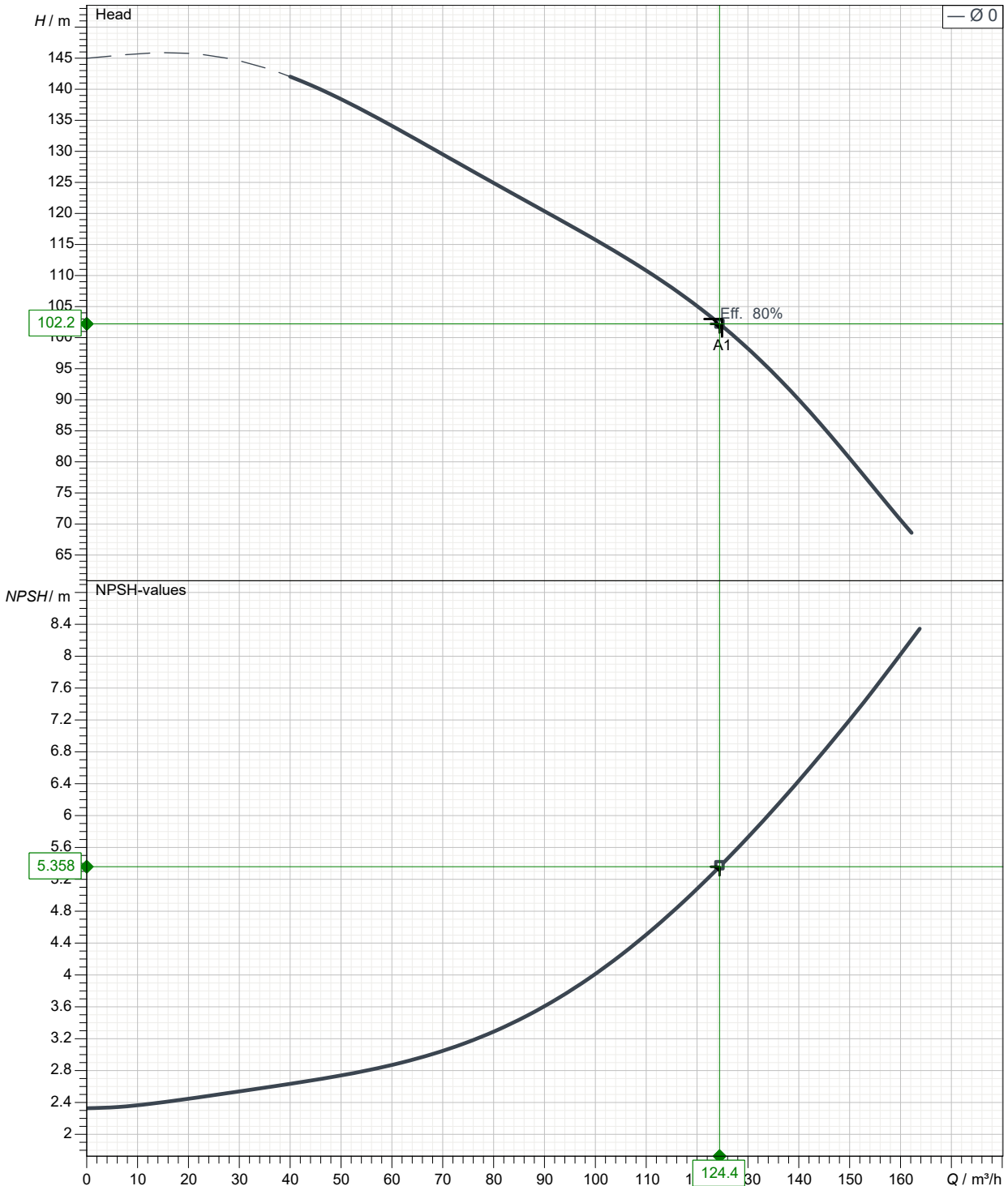



**Project Name** : Untitled project 2025-03-21 17:37:15.521

**Project ID** :

**Company Name** :  
**Department** :  
**Phone number** :  
**e-mail address** :

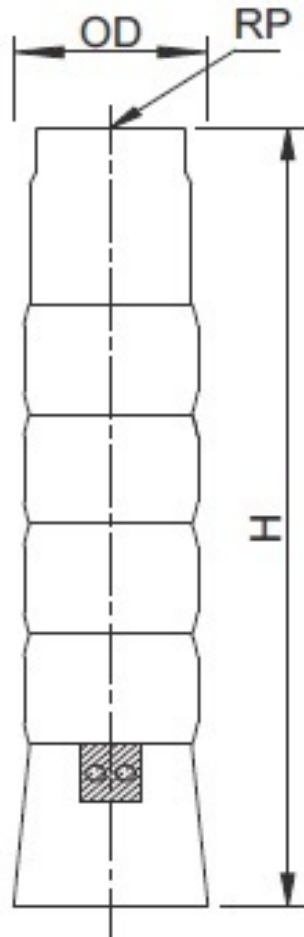

In View of continuous developments, The information/specifications/Description/ Illustrations are subject to change without notice.

**Dimensions in mm**

H	1260		
OD-DOL	204		
OD-SD	207		
RP	150		



**Project Name** : Untitled project 2025-03-21 17:37:15.521

**Project ID** :

**Company Name** :  
**Department** :  
**Phone number** :  
**e-mail address** :

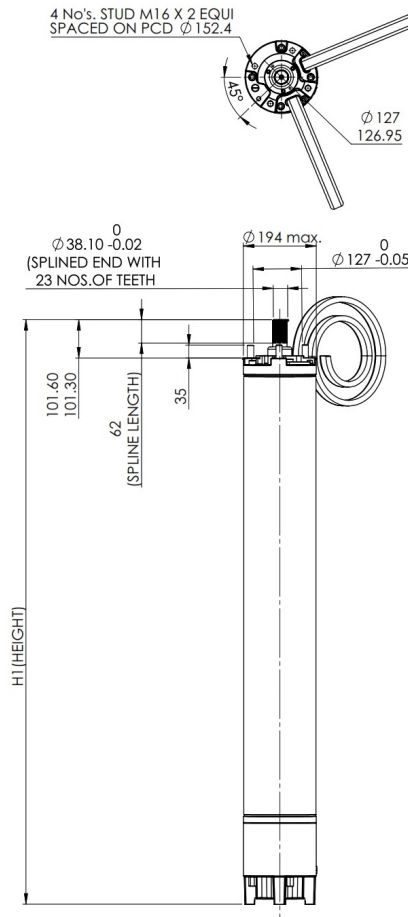

In View of continuous developments, The information/specifications/Description/ Illustrations are subject to change without notice.

## Dimensions in mm

H1	1275		
----	------	--	--



**Project Name** : Untitled project 2025-03-21 17:37:15.521  
**Company Name** :  
**Department** :  
**Phone number** :  
**e-mail address** :

**Project ID** :

**Curve Tolerance** ISO : 9906, Grade-3B

